

## PURPLE BLOOM BAG

FABRIC USED:  
BLOSSOMING BY KATHY DAVIS  
FOR FREE SPIRIT WESTMINSTER

### Fabrics:

2" X 44"	Fabric A, B, C, D, E, F, G, H, I, J
1 yd X 44"	Fabric K
14" X 24"	Pocket fabric
8" X 44"	Ruffle
10" X 10"	Flower
10" X 10"	5 fabrics that compliment the flower



### NOTIONS:

Assorted buttons for flower

45" Round elastic cord

2/3 yd Heat-n-Bond Lite

20" X 27" Super Heavy Weight Stabilizer by Bosal

2 yds X 22" Woven Fusible Interfacing by Bosal

### BODY OF BAG:

1. Cut twenty 2" X 24" strips of fabric - two each of 10 different coordinating prints. Using 1/2" seams, sew the strips together, side by side. (Fabrics – A, B, C, D, E, F, G, H, I, J). This creates a piece of fabric approximately 11" X 44". Lay the fabric on a flat cutting surface and square up the top and bottom edges.
2. Cut the new fabric in half, across the strips, and sew the two pieces together side by side, with a 1/2" seam, to create a piece of fabric approximately 22" X 22".
3. Cut the new piece of fabric across the strips to create two pieces of fabric 11" X 22"

NOTE: Continue remainder of purse using 5/8" seams.

4. Cut two 4" X 22" strips from fabric "K". Cut two 4" X 22" pieces of fusible interfacing. Fuse the interfacing to the wrong side of the fabric. With right sides together, sew one strip on the top of each of the previously created pieces. Press. See Fig 1.



Fig 1

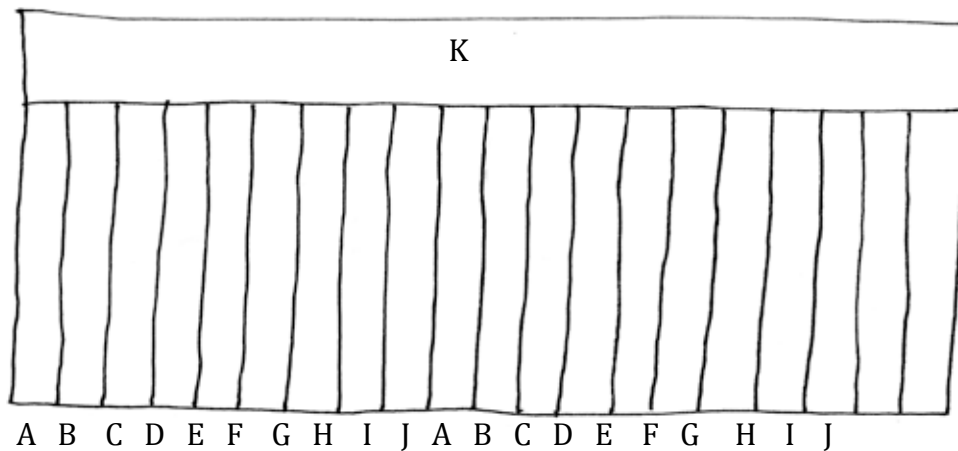

5. Cut 2 side pieces, 5" X 13", from both fabric "K" and fusible interfacing. Fuse interfacing to wrong side of fabric pieces. With right sides together, sew the sides of the bag to the front and back.

**STRAPS:**

1. Cut two straps, 3' X 27", from both fabric "K" and fusible interfacing. Fuse the interfacing to the wrong side of the fabric straps.
2. With wrong sides together, fold the handles in half, lengthwise, and press fold. Fold under 1/2" along long edges and press. Top stitch along both of the long edges 1/8" from edge.
3. Pin handles to right sides of front and back top edges 4 1/2" from side seams. See Fig 2.

Fig 2

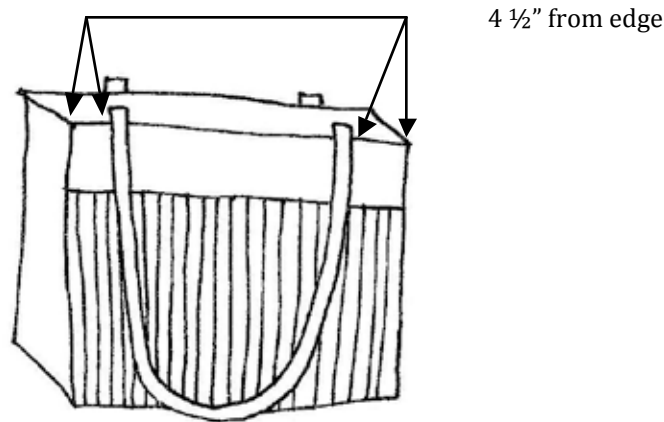

**LINING:**

1. From fabric "K", cut two pieces 13" H X 21" W for front and back lining. Cut one 4" X 21" piece for bottom and two 5" W X 13" H pieces for the ends of bag lining.

2. Cut 2 pockets 14" X 12" from a coordinating print.

3. With right sides together, fold each pocket piece in half lengthwise. Sew around 3 open sides, leaving a small opening for turning. Turn to right side, fold in opening and press. See Fig 3 for where to sew the pockets on the right side of front and back lining pieces.

With the folded edge at the top of the pocket, pin the pockets to the right side of front and back. First sew the seam dividing the pockets. Then make a 1" fold at the seam on the 9" pocket and sew down the side and bottom of that pocket only. See Fig 4.

Make two folds on the right side of the seam (12" pocket) for pens. Make a 1 1/2" fold and seam beside it and a 1 1/2" beside the first and seam next to it. Sew the remainder of the bottom pockets and right side. See Fig 5.

On the second pocket combo, eliminate the pen pockets and just sew across the sides and bottom.

Fig 3

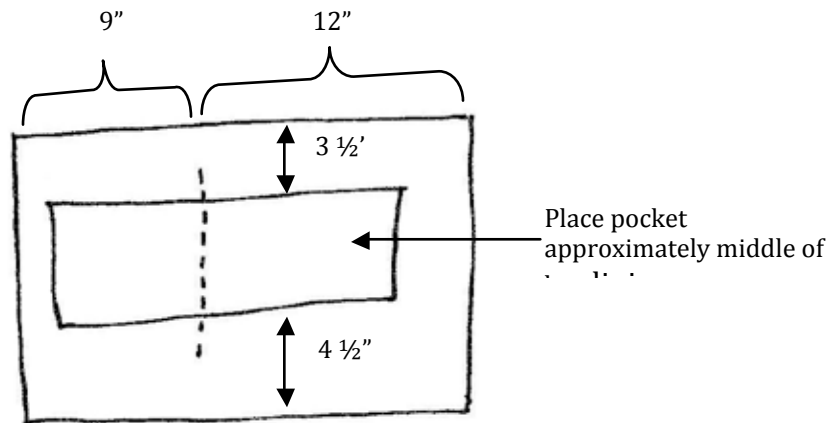

Fig 4

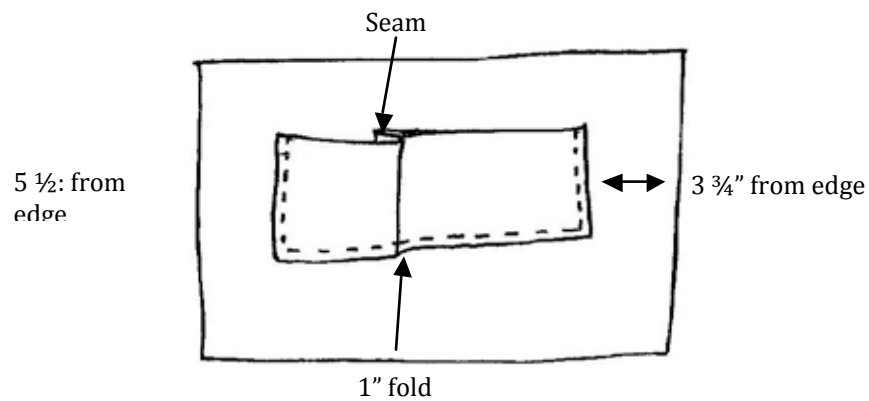
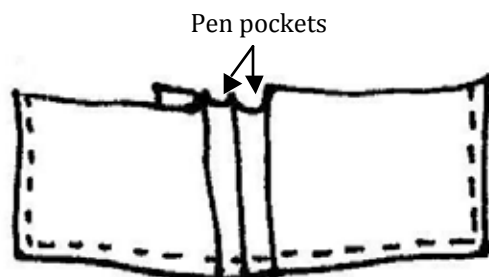
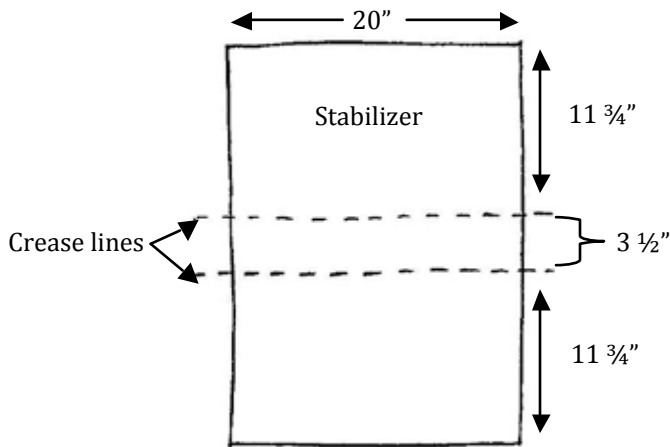

Fig 5



4. With right sides together, sew the front and back to the sides and bottom of the lining.
5. Cut one 20"W X 27"L piece of Super Heavy Weight Stabilizer.
6. Crease the stabilizer 11 3/4" down from each end. See Fig 6.

Fig 6



7. Place the stabilizer inside the top of the bag.
8. Fold the raw edges at the top of the bag over the top of the stabilizer and pin all around.
9. Insert the lining and fold in the top edges to match the bag edges. Pin in place.
10. Finish off the top of the bag by top stitching through all layers 1/8" from the edge of the top of the bag.

#### RUFFLE:

1. Cut two 4" X 44" strips of ruffle fabric and sew both ends together, forming a circle. On one end, leave a 1/2" long opening in the seam for elastic.
2. With right side out, fold the ruffle in half, down the long way, and press. Fold the raw edges in and press. Top stitch 1/8" from folded in edges.
3. Top stitch along the folded edge 3/8" from edge.
4. Thread 45" of elastic cord through opening in ruffle. Place around bag and pull as tight as needed to have the ruffle fit tightly around the bag. Secure ends of elastic and hand sew the ruffle to the bag, over the seam where fabric "K" joins the strips of fabric section.

## FLOWER:

1. Using a section of fabric that has a large flower in the pattern, cut around flower approximately 1" from the flower's edges. Apply Heat-n-Bond Lite to the wrong side of the fabric. Remove paper backing and fuse the flower to the wrong side of a scrap of fabric roughly the same size as the flower piece. See Fig 7.

Fig 7

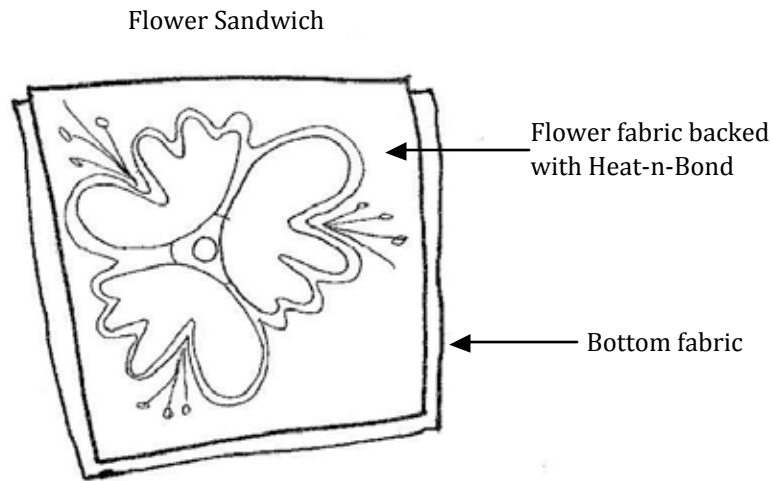

2. Cut two pieces of two complementary fabrics, roughly the same size as the above pieces.
3. Make two more fabric sandwich combos with these 4 fabric pieces and Heat-n-Bond.
4. Trim off the fabric around the flower on the 1st combo, approximately 1/8" outside the flower. See Fig 8. Cut the second combo 1/8" larger and the 3rd 1/8" larger than the 2nd. They should stack, with each being slightly larger than the one above it.

Fig 8

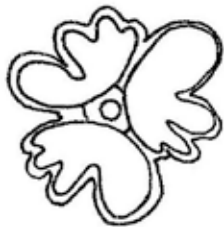

Cut around flower pattern,  
leaving 1/8" from edge of pattern

5. Free motion sew through all 6 layers, using variegated thread that will contrast, but compliment, the flower motif.
6. Bloom the flowers by putting them in the washer & dryer (add other clothes for friction)
7. Sew two complimentary buttons, stacked, to center of flower.
8. Attach the flower to the bag with needle and thread.